

INTRAY Buffer Servo

With integrated automatic buffer of trays

The INTRAY Buffer Servo is the ideal solution for a fast-moving production line or a line with little manpower available for tray refilling. The tray conveyor is built into the Smart Stand, which saves a lot of space and provides autonomy and automatic loading of new tray stack to the denester.

Buffer Servo is delivered with a custom-made Smart Tool. As in

all INTRAY products, the Buffer Servo has an easy to use integrated programmable control unit and can be easily cleaned. You also receive the time-saving Smart Tool. Using the Smart Tool, changing to a different tray is done in less than one minute.

Intelligent software

With the new version 2 software for the Buffer Servo, denesting has

never been more efficient. The new intelligent software will i.e. automatically provide correction at denesting errors, which cut back on line stops and operators having to solve denesting errors.

Technical specifications

INTRAY Buffer Servo

Specifications	
Capacity	Up to 200 trays per minute (tray depending)
Highlights	Quick restart at line stops and tray errors
	Intelligent handling of tray faults
	Backup to USB
	Multiple operator access control
	Create and store tray recipes
	Line signal in-/output

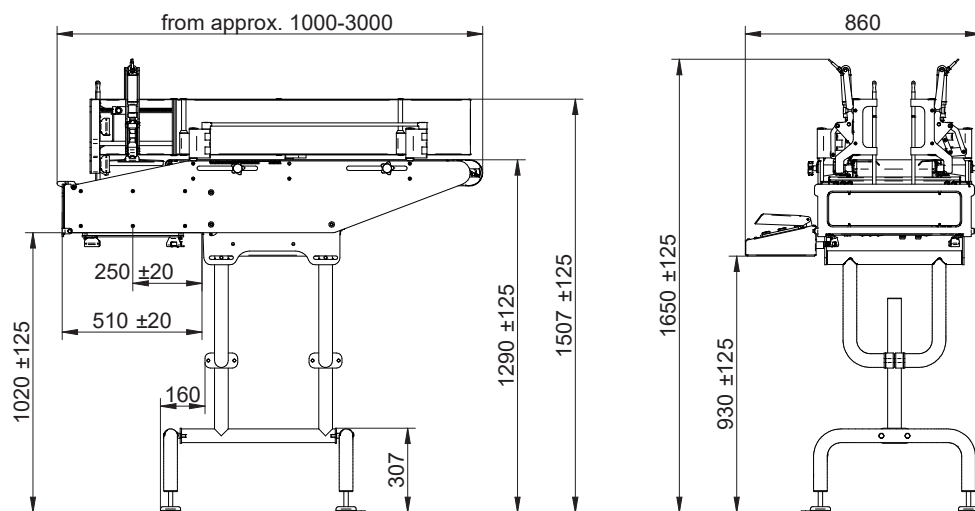

Specifications and photos are intended as a guide and can be changed by QUPAQ without notice. We make reservations for misprints and typing errors.