



INTRAY Step Conveyor

Automatic denester & conveyor to load product into trays

INTRAY Step Conveyor is an automatic denester and conveyor for loading products into trays in combination with a shuttle conveyor. It can load the tray step-by-step and if necessary also back and forth. Step Conveyor requires very little space compared to the volume and output.

With the Step Conveyor you denest directly onto a conveyor band in steps. This means you will have time

to fill in the trays - manually or with other machines - before the next tray drops and you fill the next tray with your product.

The most flexible product loading line available. With the unique step conveyor software, you can place your products in endless combinations, due to the complete placement control of the product in the tray.

Technical specifications

INTRAY Step Conveyor

Specifications	
Capacity	Up to 100 portions per minute (tray depending)
Highlights	Denests in combination with retraction belt or filling station
	Completely automatic denesting
	Loading of products directly into trays
	Can step back and forth
	Can place the product in multiple rows and layers in the tray
	Integrated programmable control unit

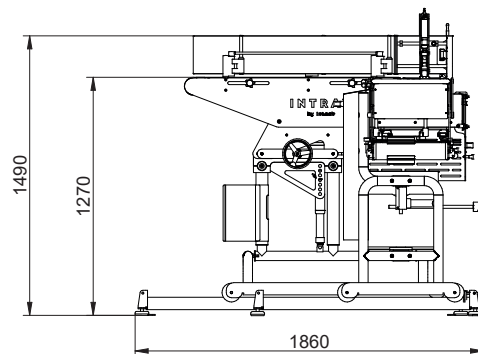
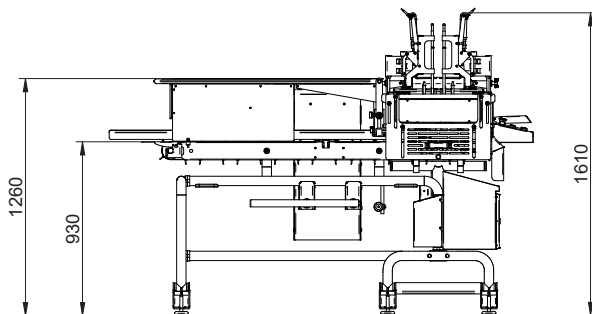

Specifications and photos are intended as a guide and can be changed by QUPAQ without notice. We make reservations for misprints and typing errors.