

QUPAQ Flex Loader High-Speed/High-Capacity Tray Loading

Versatile Efficiency

The QUPAQ Flex Loader is our most versatile and adaptable tray loader yet, engineered for flexibility and efficiency. With a compact footprint, it delivers high-speed/high-capacity performance while offering modular adjustments to suit the needs for any production line. The QUPAQ Flex Loader works with all types of tray feeding systems, and it provides limitless possibilities for the variety and quantity of products loaded into each tray.

High Capacity – Smooth Flow

By eliminating the space between trays, the QUPAQ Flex Loader enhances efficiency by reducing tray transportation time. This creates a smoother process flow, which minimizes product movement and maintains consistency. This allows the QUPAQ Flex Loader to run at high speed, while leveraging a smooth tray loading acceleration curve for optimized performance.

Recipe-Controlled Flexibility

The QUPAQ Flex Loader showcases its flexibility through precise recipe control by transitioning seamlessly within a minute between tray types of varying sizes and materials, as well as between product types like sliced and minced meats. By combining the possibilities for multi-product step-loading capabilities with straightforward single-product loading, the QUPAQ Flex Loader enhances operational efficiency and adaptability even at high capacities.

Specifications

QUPAQ Flex Loader

Technical specifications

Weight	475 kg
Power supply	3 x 400V + N + PE
Max fuse	16 A
Max short circuit current (IK Max)	6 kA
Frequency	50 Hz

Highlights

Small footprint	The modular design allows a compact inline fit - adaptable to any setup
Recipe controlled	Accommodating various trays, and product types and cuts on the same line
Tray size supported	Min. 120 x 80 x 15 mm (L x W x H) Max. 325 x 265 x 90 mm (L x W x H)
Capacity (multi-product ex. 2 or 4 per tray)	2: 260 portions/minute (130 trays/minute) 4: 260 portions/minute (65 trays/minute)
Capacity (single product)	150 portions per minute

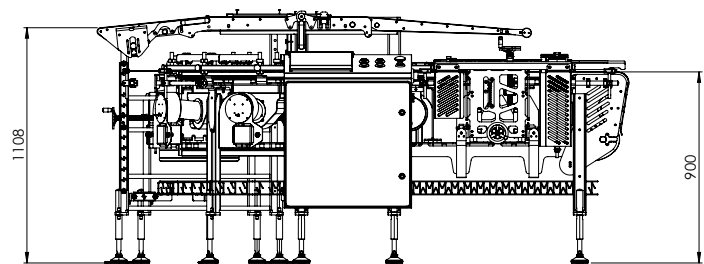
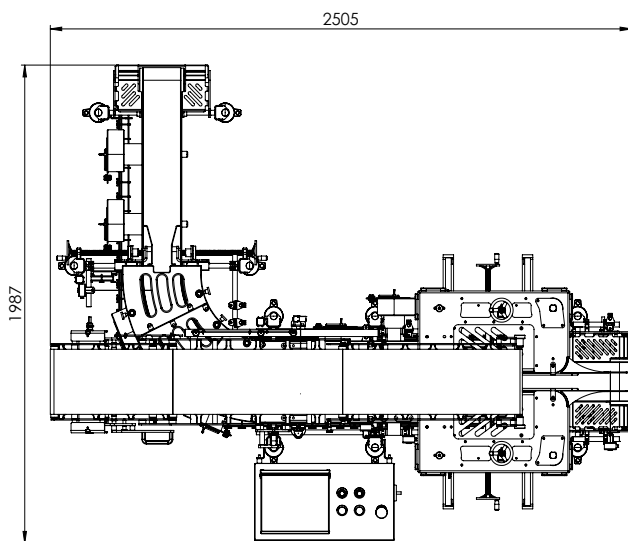

Specifications and photos are intended as a guide and can be changed by QUPAQ without notice. We make reservations for misprints and typing errors.