

# Cleanline BUFFER

## Pneumatic Denesting Solution

The ANYTRAY Cleanline Buffer is a pneumatic denester and buffer solution made to consistently provide the ANYTRAY Cleanline Tool with trays at a speed up to 120 trays per minute.

It features an easy one-minute changeover from one tool to another which enables the machine to handle trays of various sizes and shapes.

## Automatic Tray Feeding

The ANYTRAY Cleanline Buffer automatically feeds the ANYTRAY Cleanline Tool with full height trays, which results in less manual intervention and lower operation costs by ensuring a continuous production flow and fewer stops.

## Easy Integration

The ANYTRAY Cleanline Buffer is easily integrated into an existing production or packing line. Available with various buffer lengths to accommodate individual needs.

Handcrafted in Denmark using stainless steel, the ANYTRAY Cleanline Buffer features a cost-effective, low-maintenance, and hygienic design, ensuring reliability and efficiency in your production environment.

## PNEUMATIC BUFFER SOLUTION

# QUPAQ

QUALITY QUANTIFIED

# Specifications

## ANYTRAY Cleanline Buffer

Capacity	Air Consumption	Air Pressure	Voltage for Valves	Power Supply	Power Consumption	Infeed Height	Outfeed Height
Up to 120 trays per minute	300 L/min at 120 trays per min.	6 Bar	24 VDC	1 × 230V + N + PE	0.5 kWh	1315 mm (+250/-100 mm)	1000 mm (+250/-100 mm)

Humidity	Operational Temperature	Max SCCR (Ik Max)	Noise Level	Full-load Current	Frequency	Weight	Steel Quality
Min. 10% Max. 90%	5°-40° C	6 kA	< 75 dB	2A	50 Hz	Approx. 200 kg	EN 1.4301 AISI 304

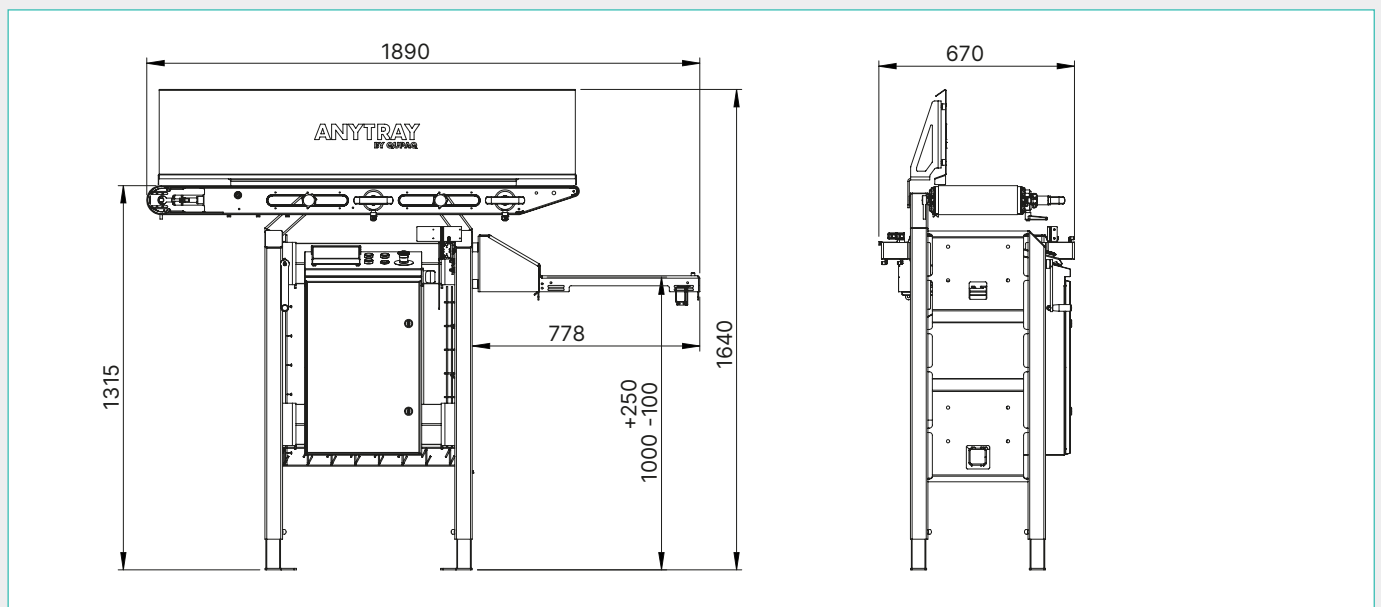

Specifications and photos are intended as a guide and can be changed by QUPAQ without notice. We make reservations for misprints and typing errors. The illustration and specifications are of the ANYTRAY Cleanline Buffer - 1500. Item no. 6010040314.

# QUPAQ

QUALITY QUANTIFIED

**QUPAQ**  
Erhvervsparken 16  
9700 Broenderslev  
Denmark

P. +45 96 46 76 00  
qupaq@qupaq.com  
qupaq.com